

SOAP DISPENSER

- Tank Type — Vertical
- Surface Mounted

Bradex™

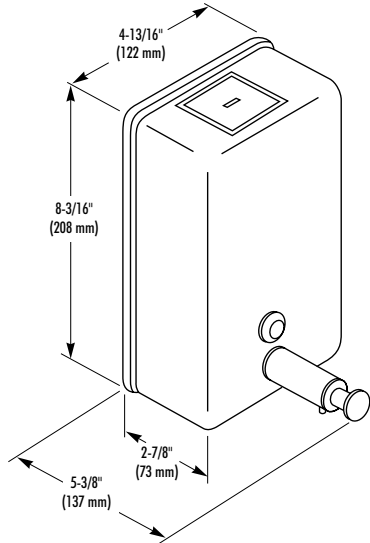

MODEL 6562

CONSTRUCTION:

- **BODY** fabricated of type 304 (18-8), 20 gauge stainless steel with exposed surfaces in architectural satin finish.
- **BACK** fabricated of type 304 (18-8), 20 gauge stainless steel. Heliarc welded to the body.
- **WALL PLATE** of heavy gauge stainless steel.
- **SOAP VALVE** has chrome plated brass housing with ABS plastic mechanism.

CAPACITY:

40 oz. liquid soap.

OPERATION:

Push-in valve dispenses measured amount of vegetable or coconut oil liquid soaps, synthetic detergents, and antiseptic solutions. Sight gauge indicates refill time. Locked filler top opens with special key provided.

INSTALLATION:

Secure separate mounting bracket to wall. Slide dispenser into place and secure locking screw through filler hole.

OPTIONAL FEATURES:

| Feature | Suffix |
|--|--------|
| <input type="checkbox"/> Lather soap valve in lieu of liquid | -13 |

GUIDE SPECIFICATION:

Surface mounted liquid soap dispenser shall be fabricated of 20 gauge satin finish stainless steel. Dispenser shall have completely concealed mounting, vandal-resistant filler hole cover and sight gauge. Push-in corrosion-resistant liquid soap valve. Capacity: 40 oz. liquid soap.

Overall dimensions: 4-13/16"W x 8-3/16"H x 2-7/8"D.

Surface Mounted Liquid Soap Dispenser shall be Bradley Model 6562.

Orders composed of products indicated as **Bradex™** will be available to ship in one week after receipt of order at the factory. There is no pricing penalty for this service from Bradley.

Document No. 8690

This information is subject to change without formal notice.
1299RSSCJ

Bradley

P.O. Box 309, Menomonee Falls, WI 53052-0309
Phone 1-800-BRADLEY FAX 262-253-4161
Web Site: <http://www.bradleycorp.com>
Technical Information Fax Service: 1-800-BRADFAX