

Model 100-EH

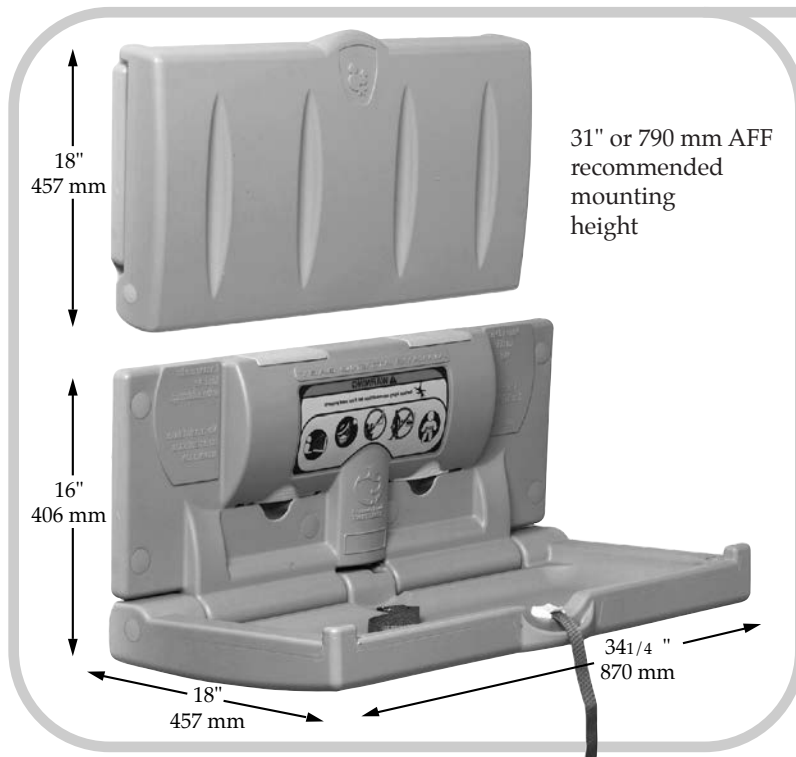

- Rated to support a static load of 250 pounds (113 kg); tested to 390 pounds (177 kg).
- Easy to clean, high-density polyethylene which inhibits bacterial growth.
- Standard with molded-in dual liner dispensers.
- Each liner dispenser holds approximately 50 of the 036-LCR liners.
- Safety belt with cam-buckle is adjustable with one hand.
- Convenient bag hooks on both sides.
- Easy to read ANSI compliant labels (ANSI Z535.3 and ANSI Z535.4).
- Compact, slim profile. Only protrudes 4 inches or 102 mm from wall.
- Pneumatic gas shock mechanism to ensure smooth, safe open and close motions.
- Includes easy to install, step-by-step instructions plus all mounting hardware.
- ASTM G21 Anti-Bacterial: No measurable bacterial growth.
- ASTM G22 Anti-Fungal: No measurable fungal growth.
- Standard pack: 1 unit.

Recommended Blocking

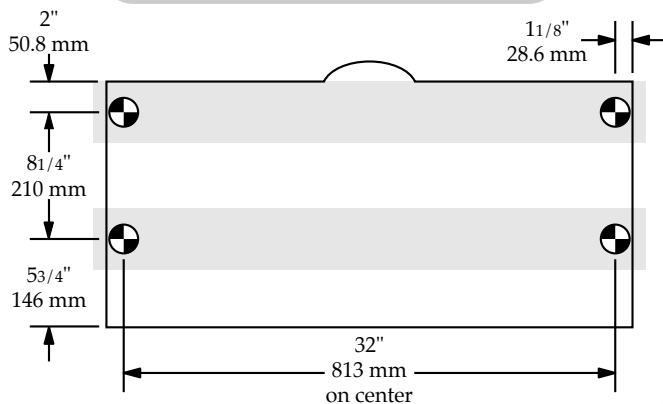

A.D.A. Compliance*



- 4.4.1 Max. Protruding Objects
 - 4.2.5 Forward Reach
 - 4.2.6 Parallel Approach
 - 4.27.4 Operation
- * Compliant when properly installed.

Short Specification

Polyethylene Diaper Changing Stations:

1. Acceptable product: Brocar Products, Inc.; Model 100-EH.
2. Characteristics:
 - a. Type: Molded FDA approved high-density polyethylene (HDPE) body.
 - b. Child protection strap featuring cam-buckle which is adjustable with one hand.

- Limited Warranty: This product is warranted against manufacturing defects for a period of one year. This warranty is in lieu of all other warranties, express or implied, including any implied warranties regarding merchantability or fitness for a particular purpose, relating to the use of performance of this product.

- Product Liability Insurance: General liability \$1,000,000. Excess liability \$10,000,000.